

# Distributed System for Monitoring of Physiological Parameters in Web-based Personal Health Systems

Mitko Petrov Shopov, Nikolay Rumenov Kakanakov and Grisha Valentinov Spasov

**Abstract** - Paper presents a Web-based Personal Health System (PHS) for remote monitoring of ECG signals. It presents a multi-tiered architecture for building PHS and integrating them with enterprise and health information systems. Tiers encompass Body Area Network (BAN) with medical sensors, Personal Server and/or Home gateway, Medical servers and Web Portal. A use case scenario for remote ECG monitoring is described in the paper for proving the effectiveness of the proposed architecture. The uploaded ECG data can be viewed and analyzed remotely by the specialists. The patient (at patient site) also can log in the medical portal and can upload data file with its ECG.

**Keywords** – Personal Health System, ECG, remote monitoring.

## I. INTRODUCTION

New and emerging concepts like mobile health (m-Health) and Personal Health Systems (PHS) are expected to revolutionize the way the healthcare services are delivered. The healthcare services are moving to patient-centric models. M-Health incorporates mobile computing, medical sensors and wireless communication technologies for delivering of healthcare in a non-restrictive manner. It is also defined as the next step in the continuous shift from traditional desktop telemedicine systems toward new wireless, mobile and unobtrusive healthcare platforms. Patients will be able to make some of the medical tests at home guided remotely by the specialist or general practitioner using wearable sensors, implants and mobile medical assistants. The results from these tests will be stored in electronic medical records on medical servers and accessed from everywhere and anyone with the right credentials.

The goal of this paper is to examine the design and implementation steps in the process of development of Web-based PHS systems and to present an initial implementation of a distributed system for remote monitoring of ECG signals.

## II. BACKGROUND AND RELATED WORK

Extensive works has been undertaken on the design and

M. Shopov is with the Department of Electronics, Faculty of Electronics and Automatics, Technical University – Sofia, branch Plovdiv, 61 St. Petersburg Blvd., 4000 Plovdiv, Bulgaria, e-mail: mshopov@tu-plovdiv.bg

N. Kakanakov is with the Department of Computer Systems and Technologies, Faculty of Electronics and Automatics, Technical University – Sofia, branch Plovdiv, 61 Sankt Petersburg Blvd., 4000 Plovdiv, e-mail: kakanak@tu-plovdiv.bg

G. Spasov is with Department of Computer Systems and Technologies, Faculty of Electronics and Automatics, Technical University – Sofia, branch Plovdiv, 61 Sankt Petersburg Blvd., 4000 Plovdiv, e-mail: gvs@tu-plovdiv.bg

development of Personal Health Systems (PHS). Chenhui et al. in [3] focus their work on the integration of different Health Information Systems (HIS) and other enterprise systems to achieve seamless interoperation. The chosen approach is to build the system around an integration engine. The engine is responsible for the understanding of message context, converting the healthcare information into a unified format, and storing the information in data repositories. The communication of information systems with different integration interfaces is done through appropriate engine interface adaptors. The paper provides techniques for integration of existing systems rather than structure of such systems.

Several works focus on systems for remote monitoring of medical parameters across Internet. Bonho et al. in [2] suggest a microprocessor-based system called Internet server that uses real-time communication protocol to deliver measured data in real-time to remote computer. The Internet server uses Bluetooth connection to access ECG sensor data. Other authors [4], [6], [11] rely on standard mobile devices to acquire data from wireless on-body sensor using Personal Area Network (PAN). The mobile device accesses the remote storage server either through wireless wide area networks (GPRS) or Wireless Local Area Networks (WLAN). Lovell et al. [10] suggest the use of Web to access patient records. The described system uses multitiered architecture with additional server for data processing. The negative aspect of this work is the dependency of software products of a single vendor, which is not suitable in the heterogeneous environment of such kind of systems.

Another group of authors focuses their work on the use of Service Oriented Architecture (SOA) and Web services in the design and development of PHS systems [7], [8]. The both works suggest SOA as a foundation paradigm in the design of e-Health systems. The implementation is based on the Web services technology.

## III. MULTI-TIERED ARCHITECTURES FOR PHS

In the design of PHS systems the current best practices dictate the use of architectural models that combine hierarchical and distributed approaches. In vertical aspect the architectures of PHS system is naturally hierarchical and is usually separated into tiers representing one or more of the building blocks of the system. The tiered architecture brings flexibility and separation of presentation and functional roles within the healthcare process. The additive benefits are increased security, information generalization, data reasoning and functional isolation.

From the patient-centric view of the PHS, the system architecture is usually represented into tree tiers [6], [9], [12]. The exact system architecture and the number of system tiers depend predominantly on target applications,

available infrastructure, type and number of users. Figure 1 shows an abstract architecture of PHS system. For the purposes of clarity the lowest two tiers are represented separately, although usually they are grouped in a single tier. The first tier is formed around BSN (fig. 1) and performs the functions of collecting, processing and communicating of medical data from sensors to the next tier. It could include also data from other available sources such as ambient sensors situated in home and offices. The communication with next tier is based on one of the wireless standards from IEEE 802.15 (WPAN) family.

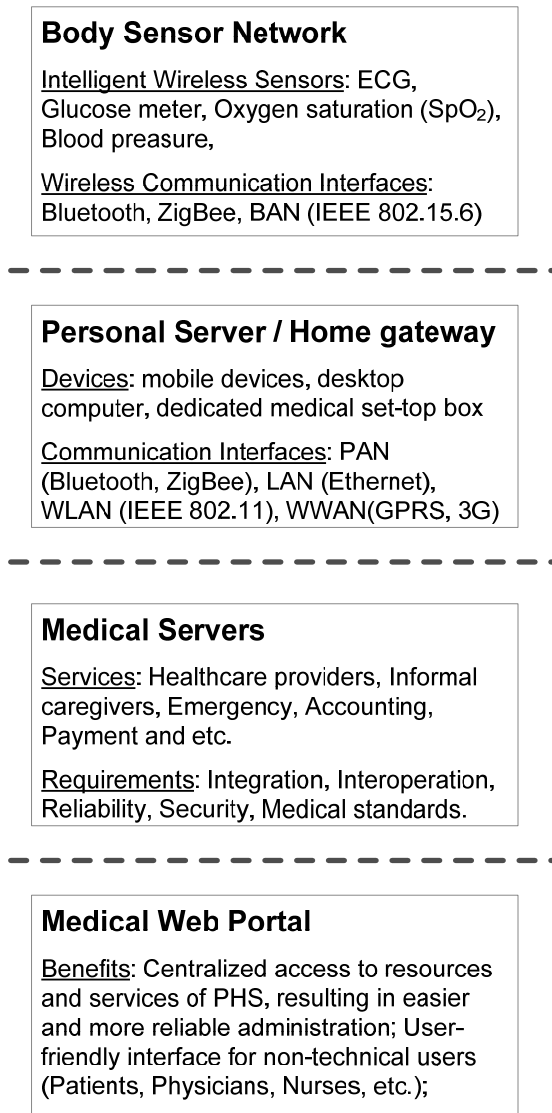

FIG. 1: TIERS OF PHS SYSTEM' ARCHITECTURE

Second tier encompasses the personal server and/or home gateway. Personal server is a mobile device like smart phone or PDA. It brings the advantage to be in constant connection to BSN, but has power and energy limitations. Home gateway on other hand is a desktop computer or dedicated medical set-top box device with custom designed microcontroller. It could support most of the existing communication interfaces, including wired and wireless, and to use the advantage of Internet for wide bandwidth, low-cost data transmissions. It could realize some local data storage and processing over data from BSN to save time and reduce cost.

The Medical servers tier consists of various healthcare services. For increased interoperability, scalability, easier integration with other health and enterprise systems, and rapid development this tier is build on top of SOA design paradigm. The Service Oriented Architecture brings software architecture principles such as abstraction, encapsulation, modularization and software reuse. It separates the interface and implementation of the services and provides well-defined interfaces for client applications. The function of this tier includes control of data exchange with personal server and home gateway, management and support of database with electronic medical records, interface to various medical and non-medical services, global processing over data from BSN and feedback to the patient.

The server working on the last tier is called Medical Web portal and can be based on a portal technology [13] or dynamic web server technologies [15]. It acts as a central access point for resources and services of the system. This simplifies the administration and implementation of the user-interface and allows easier integration with other healthcare and enterprise information systems and easier access. It could be implemented using proven best-practises for design of Web applications.

#### IV. USE-CASE SCENARIO – DISTRIBUTED SYSTEM FOR REMOTE ECG MONITORING

In this section, an example implementation of remote ECG monitoring application is presented. Depending on whether a home gateway, personal server or both are used, three possible scenarios can be evaluated [11]. In this paper the scenario with home gateway is used (figure 2). The scenario consists of a wireless ECG data acquisition system [5], a bluetooth-enabled workstation with Internet connection and a Medical server.

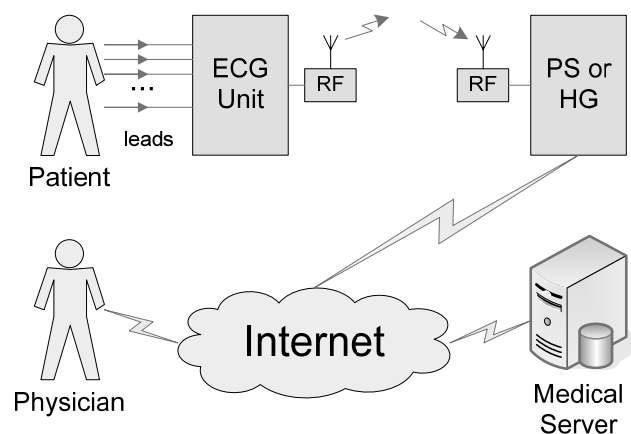

PS – Personal Server; HG – Home Gateway

FIG. 2: SYSTEM BLOCK DIAGRAM FOR REMOTE ECG MONITORING

The ECG system is equipped with a Bluetooth wireless connection. The control and data acquisition is done through custom software application working on a workstation and must be in the Bluetooth range (10-20m). The data is transferred in raw format. Every ECG data is associated with patient profile. The application is capable of local data visualization and manipulation of collected ECG data.



FIG. 3: SVG VISUALIZATION OF ECG SIGNALS

To extend the accessibility of measured ECG data to its users in various locations a medical server is introduced. Medical server encompasses a Web and a database server. It plays the role of central repository and is build upon well-known enterprise technologies with their build-in benefits as security (secure places, secure connections), availability (server clusters, backup connections), reliability (UPS, RAID, data replication) and etc.

Once delivered to the Medical server the data is stored in database and accessed through the Web interface (fig. 3). The visualization of ECG signals is based on Scalable Vector Graphics (SVG) [14]. SVG is a language for describing two-dimensional vector graphics and graphical applications in XML. Since SVG images and their behaviours are defined in XML text files, they can be searched, indexed, scripted and compressed, if necessary. The SVG Basic and SVG Tiny specifications target small and mobile devices. Most of the popular Web browsers comes with built-in SVG support except Internet Explorer that needs an external plugin to be installed.

The implementation of SVG ECG graphics uses Batik toolkit [1]. Batik is a Java-based toolkit for applications or applets that want to use images in the Scalable Vector Graphics (SVG) format for various purposes, such as display, generation or manipulation.

Every user of the system has an account on the Medical server with associate role and permissions. The patient role (at patient site) can update its profile information and can upload new ECG data files to its database (manually or through the local ECG application). The physician role has permissions to view and analyse ECG data of all patients

associate with him. In the analysis of the data several filters and tools are available for use. The manager role is responsible for assignment of patient-physician relationship and other system management tasks.

Figure 3 shows a view of the Web-based client interface for visualization of pre-stored ECG signals.

## V. CONCLUSIONS AND FUTURE WORK

The multi-tier architecture for realization of Web-based PHS presented in the paper provides a base for integration of health information systems and personal health monitors. It can be used for web-enabling of the existing medical monitoring applications and to bring the e-health closer to its users. Distribution of different tiers could provide monitoring of critical patients in remote places.

The use-case scenario is used as prove of concept of the presented architecture. It also presents a working system for remote ECG viewing and sharing ECG data between patients, general practitioners and specialists.

Future work includes further automation of the processing and delivery of sensed data to medical servers. The ECG module can incorporate local storage and local preprocessing capability thus reducing required bandwidth and power consumption. The next step is automation of data delivery from home gateway to remote medical server.

Another area for future work is to incorporate approved and perceived international standards such as the HL7 family of standards and DICOM in the implementation of the system where appropriate.

## V. ACKNOWLEDGEMENTS

The presented work is supported by Technical University of Sofia, project "091ni066-17/2009" – entitled "Web-based experimental network for analysis of data flows and traffics in personal health systems (WebPHS)" under contract "091ni066-17/2009".

## REFERENCES

- [1] Batik SVG toolkit, Available at: <http://xmlgraphics.apache.org/batik/>, Accessed June 2009.
- [2] Bonho S., D. Kolm, J. Baggio, and R. Moraes, *Microprocessor-Based System to ECG Monitoring Through Internet*, IFMBE Proceedings, vol. 14/6, pp. 4008-14011, Springer Berlin Heidelberg, ISSN: 1680-0737, 2007.
- [3] Chenhui, Z., Huilong D., Xudong, L., *An integration Approach of Healthcare Information System*, Proc. IEEE Conf. on Biomedical Engineering and Informatics, pp. 606-609, 2008.
- [4] Fensli, R., E. Gunnarson, T. Gundersen, *A wearable ECG-recording system for continuous arrhythmia monitoring in a wireless tele-home-care situation*, Proc. Symposium on Computer-based Medical Systems (CBMS'05), pp.407-412, 2005.
- [5] Iliiev I., Tsvetanov D., Matveev M., Naydenov S., Krasteva V., Mudrov N., *Implementation of high resolution wireless ECG data acquisition system in intensive coronary care unit*, Proc. International Conference Advanced Information and Telemedicine Technologies for Health '2005, Minsk, Belarus, pp. 79-84, November 2005.
- [6] Istepanian R., Jovanov, E., and Zhang Y.T., *Beyond Seamless Mobility and Global Wireless Health-Care Connectivity*, IEEE Transactions on Information Technology in Biomedicine, vol. 8, no. 4, pp. 405-441, Dec. 2004.
- [7] Kart, F., G. Miao, L. Moser, P. Melliar-Smith, *A distributed e-Healthcare system based on the Service Oriented Architecture*, pp.652-659, 2007.
- [8] Lee, C. M. Lee; D. Han, S. Jung, J. Cho, *A framework for personalized Healthcare Service Recommendation*, e-Health Networking, Applications and Services, 2008. HealthCom 2008. 10th International Conference, pp.90-95, 7-9 July 2008.
- [9] Lee, H., Lee, S., Ha, K., Jang, H., Chung, W., Kim, J., Chang, Y., and Yoo, D., *Ubiquitous healthcare service using Zigbee and mobile phone for elderly patients*, Journal of Medical Informatics, vol. 78, pp.193-198, 2008.
- [10] Lovell, N., F. Magrabi, B. Celler, K. Huynh, and H. Garsden, *Web-based acquisition, storage, and retrieval of biomedical signals*, IEEE Engineering in medicine biology, pp. 38-44, 2001.
- [11] Milenkovic, A., C. Otto, E. Jovanov, *Wireless sensor networks for personal health monitoring: Issues and an implementation*, Journal of Computer Communications (Special issue: Wireless Sensor Networks: Performance, Reliability, Security and Beyond), Elsevier, 2006.
- [12] Shopov, M., G. Spasov, G. Petrova, *Architectural models for realization of Web-based Personal Health Systems*, Proc. International Conference on Computer Systems and Technologies (CompSysTech'2009), IIIB.5., June, 2009.
- [13] Apache Software Foundation, Apache Portals Project, Available at: <http://portals.apache.org/>, Accessed June 2008.
- [14] Scalable Vector Graphics (SVG), Available at: <http://www.w3.org/Graphics/SVG/>, Accessed June 2009.
- [15] Sun Microsystems, Inc, JavaServer Pages Technology, Available at: <http://java.sun.com/products/jsp/>, Accessed June 2009.